

TECHNICAL MANUAL

ORGANIZATIONAL, DIRECT SUPPORT AND
GENERAL SUPPORT MAINTENANCE
REPAIR PARTS AND SPECIAL TOOLS LIST

FOR

RADIO TEST SET AN/PRM-34
(NSN 6625-01-094-5646)

Technical Manual

HEADQUARTERS
DEPARTMENT OF THE ARMY

No. 11-6625-3015-24P

Washington, DC, 25 February 1984

ORGANIZATIONAL, DIRECT SUPPORT AND
GENERAL SUPPORT MAINTENANCE
REPAIR PARTS AND SPECIAL TOOLS LIST
FOR
RADIO TEST SET AN/PRM-34
(NSN 6625-01-094-5646)

Current as of 9 January 1984

REPORTING ERRORS AND RECOMMENDING IMPROVEMENTS

You can help improve this manual. If you find any mistakes or if you know of a way to improve the procedures, please let us know. Mail your letter, DA Form 2028 (Recommended Changes to Publications and Blank Forms), or DA Form 2028-2 located in the back of this manual direct to: Commander, US Army Communications-Electronics Command and Fort Monmouth, ATTN: DRSEL-ME-MP, Fort Monmouth, New Jersey 07703.

In either case, a reply will be furnished direct to you.

TABLE OF CONTENTS

	Page	Illus Figure
Section I. Introduction	1	
II. Repair Parts List	5	
Group 00 Radio Test Set AN/PRM-34	5	1
01 Test Set Radio TS-3951/PRM-34	7	2
Section III. Special Tools List (Not applicable)		
IV. National Stock Number and Part Number Index	8	

SECTION I INTRODUCTION

1. Scope

This manual lists spares and repair parts; special tools; special test, measurement, and diagnostic equipment (TMDE), and other special support equipment required for performance of organizational, direct support, and general support maintenance of the AN/PRM-34. It authorizes the requisitioning and issue of spares and repair parts as indicated by the source and maintenance codes.

2. General

This Repair Parts and Special Tools List is divided into the following sections:

a. Section II. Repair Parts List. A list of spares and repair parts authorized for use in the performance of maintenance. The list also includes parts which must be removed for replacement of the authorized parts. Parts lists are composed of functional groups in numeric sequence, with the parts in each group listed in figure and item number sequence.

b. Section III. Special Tools List. Not applicable.

c. Section IV. National Stock Number and Part Number Index. A list, in National item identification number (NIIN) sequence, of all National stock numbers (NSN) appearing in the listings, followed by a list, in alphameric sequence, of all part numbers appearing in the listings. National stock numbers and part numbers are cross-referenced to each illustration figure and item number appearance.

3. Explanation of Columns

a. Illustration. This column is divided as follows:

(1) Figure number. Indicates the figure number of the illustration on which the item is shown.

(2) Item number. The number used to identify item called out in the illustration.

b. Source, Maintenance, and Recoverability (SMR) Codes.

(1) Source code. Source codes indicate the manner of acquiring support items for maintenance, repair, or overhaul of end items. Source codes are entered in the first and second positions of the Uniform SMR Code format as follows:

<u>Code</u>	<u>Definition</u>
PA --	Item procured and stocked for anticipated or known usage.
PF --	Support equipment which will not be stocked but which will be centrally procured on demand.
XA --	Item is not procured or stocked because the requirements for the item will result in the replacement of the next higher assembly.
XB --	Item is not procured or stocked. If not available through salvage, requisition.

NOTE

Cannibalization or salvage may be used as a source of supply for any item source coded above except those coded XA and aircraft support items as restricted by AR 750-1.

(2) Maintenance code. Maintenance codes are assigned to indicate the levels of maintenance authorized to USE and REPAIR support items. The maintenance codes are entered in the third and fourth positions of the Uniform SMR Code format as follows:

(a) The maintenance code entered in the third position will indicate the lowest maintenance level authorized to remove, replace, and use the support item. The maintenance code entered in the third position will indicate one of the following levels of maintenance:

<u>Code</u>	<u>Application/Explanation</u>
0 --	Support item is removed, replaced, used at the organizational level.
H --	Support item is removed, replaced, used at the general support level.

(b) The maintenance code entered in the fourth position indicates whether the item is to be repaired and identifies the lowest maintenance level with the capability to perform complete repair (i.e., all authorized maintenance functions). This position will contain one of the following maintenance codes:

<u>Code</u>	<u>Application/Explanation</u>
D --	The lowest maintenance level capable of complete repair of the support item is the depot level.
Z --	Nonreparable. No repair is authorized.

(3) Recoverability code. Recoverability codes are assigned to support items to indicate the disposition action on unserviceable items. The-recoverability code is entered in the fifth position of the Uniform SMR Code format as follows:

<u>Recoverability codes</u>	<u>Definition</u>
Z --	Nonreparable item. When unserviceable, condemn and dispose at the level indicated in position 3.
D --	Reparable item. When beyond lower level repair capability, return to depot. Condemnation and disposal not authorized below depot level.

c. National Stock Number. Indicates the National stock number assigned to the item and will be used for requisitioning purposes.

d. Federal Supply Code for Manufacturer (FSCM). The FSCM is a 5-digit numeric code listed in SB 708-41/42 which is used to identify the manufacturer, distributor, or Government agency, etc.

e. Part Number. Indicates the primary number used by the manufacturer (individual, company, firm, corporation, or Government activity), which controls the design and characteristics of the item by means of its engineering drawings, specifications, standards, and inspection requirements to identify an item or range of items.

NOTE

When a stock numbered item is requisitioned, the repair part received may have a different part number than the part being replaced.

f. Description. Indicates the Federal item name and, if required, a minimum description to identify the item.

g. Unit of Measure (U/M). Indicates the standard of the basic quantity of the listed item as used in performing the actual maintenance function. This measure is expressed by a two-character alphabetical abbreviation (e.g., ea, in, pr, etc). When the unit of measure differs from the unit of issue, the lowest unit of issue that will satisfy the require units of measure will be requisitioned.

h. Quantity Incorporated in Unit. Indicates the quantity of the item used in the breakout shown on the illustration figure, which is prepared for a functional group, subfunctional group, or an assembly.

4. Special Information

a. The following publication pertains to the AN/PRM-34 and its components:

TM 11-6625-3015-14, Radio Test Set AN/PRM-34.

b. National stock numbers (NSN's) that are missing from P source coded items have been applied for and will be added to this TM by future change/revision when they are entered in the Army Master Data file (AMDF). Until the NSN's are established and published, submit exception requisitions to: Commander, US Army Communications-Electronics Command and Fort Monmouth, ATTN: DRSEL-MM, Fort Monmouth, New Jersey 07703 for the part required to support your equipment.

5. How to Locate Repair Parts

a. When National stock number or part number is unknown.

(1) First. Using the table of contents, determine the functional group within which the item belongs. This is necessary since illustrations are prepared for functional groups and listings are divided into the same groups.

(2) Second. Find the illustration covering the functional group to which the item belongs.

(3) Third. Identify the item on the illustration and note the illustration figure and item number of the item.

(4) Fourth. Using the Repair Parts Listing, find the figure and item number noted on the illustration.

b. When National stock number or part number is known.

(1) First. Using the Index of National Stock Numbers and Part Numbers, find pertinent National stock number or part number. This index is in NIIN sequence followed by a list of part numbers in alpha-merit sequence, cross-referenced to the illustration figure number and item number.

(2) Second. After finding the figure and item number, locate the figure and item number in the repair parts list.

6. Abbreviations

Not applicable.

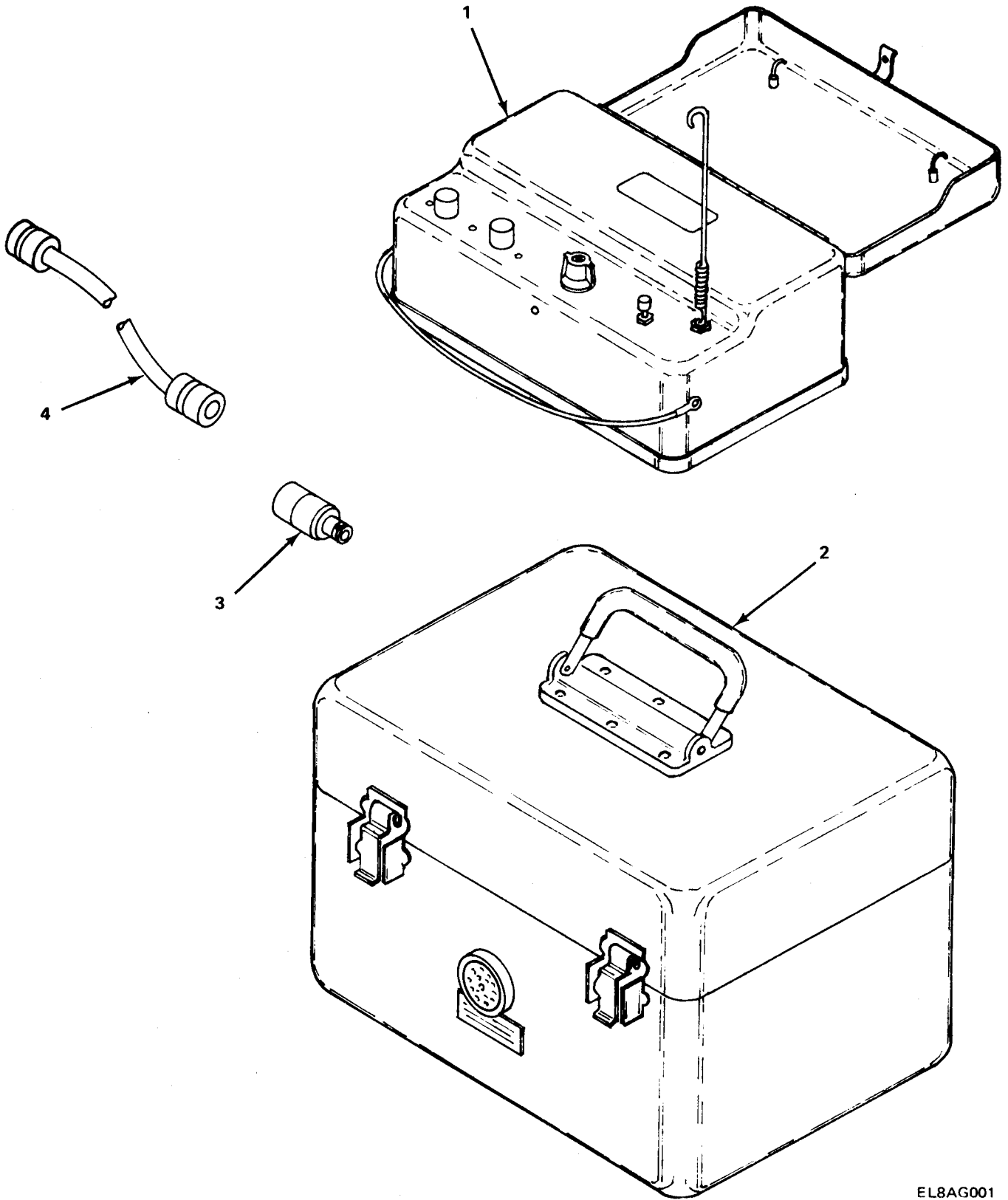

EL8AG001

Figure 1. Radio Test Set AN/PRM-34.

SECTION II (1) ILLUSTRATION		(2)	(3)	TM11-6625-3015-24P		(6)	(7)	(8)
(A) FIG NO	(B) ITEM NO	SMR CODE	NATIONAL STOCK NUMBER	(4) FSCM	(5) PART NUMBER	DESCRIPTION	USABLE ON CODE	QTY INC IN UNIT
GROUP 00 RADIO TEST SET AN/PRM-34								
1	1	PFODD	6625-01-119-9910	80058	TS-3951/PRM-34	TEST SET,RADIO	EA	1
1	2	XBHZZ		56996	B4029277		EA	1
1	3	PADZZ	5985-01-097-7337	37695	914598-801	ANTENNA ADAPTOR ASY	EA	1
1	4	PADZZ		05726	2249C24	CABLE ASSY,RF	EA	1
NOTE								
BATTERY, LITHIUM SULPHER DIOXIDE BA-5847/U, NSN 6135-01-090-5364, CAN BE REQUISITIONED THROUGH NORMAL SUPPLY CHANNELS.								

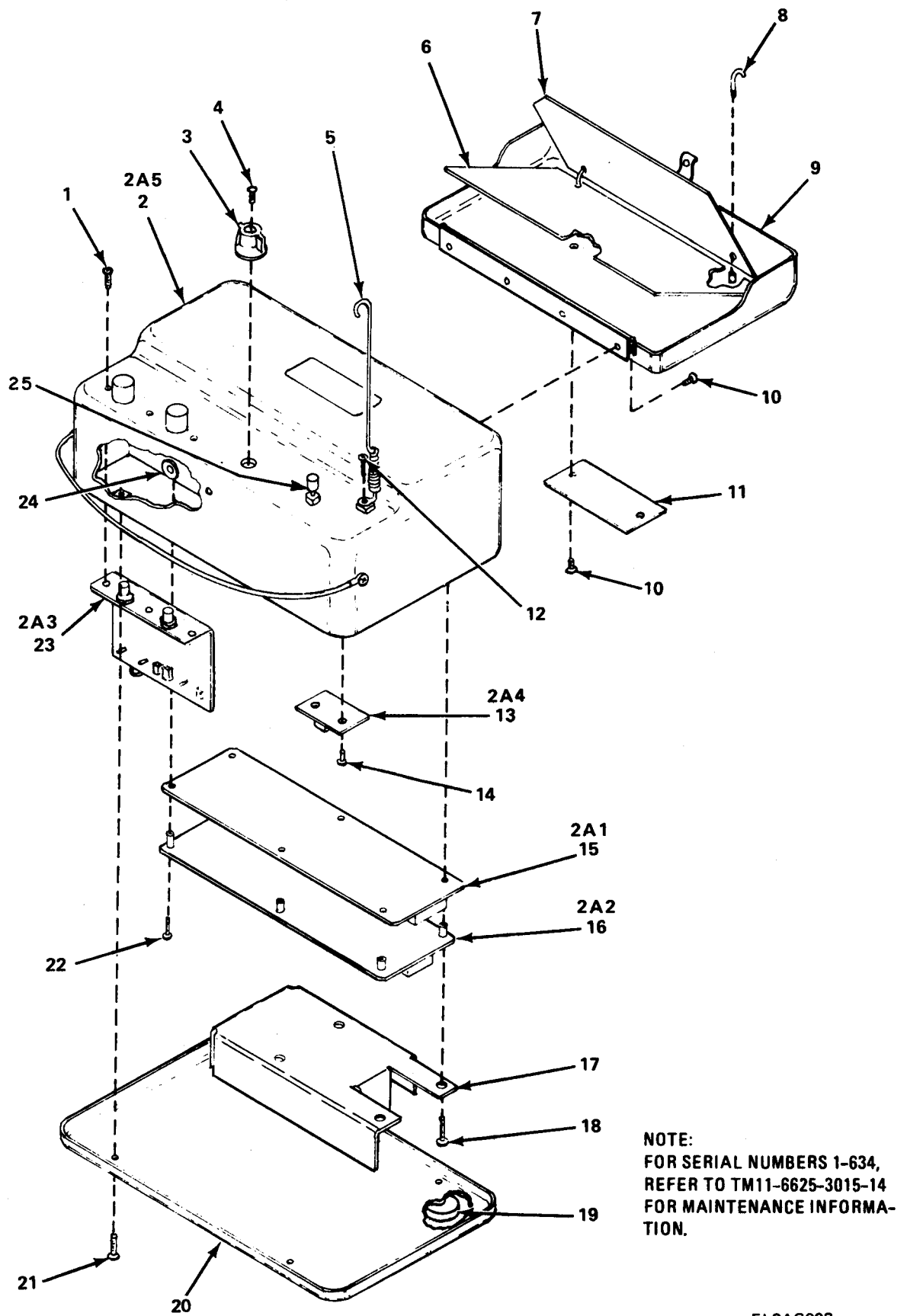

EL8AG002

Figure 2. Test Set Radio TS-3951/PRM-34.

SECTION II (1) ILLUSTRATION		(2)	(3)	TM11-6625-3015-24P		(6)	(7)	(8)
(A) FIG NO	(B) ITEM NO	SMR CODE	NATIONAL STOCK NUMBER	(4) FSCM	(5) PART NUMBER	DESCRIPTION	USABLE ON CODE	U/M
						GROUP 01 TEST SET RADIO TS-3951/PRM-34		
2	1	PAHZZ		97539	R-4-40X1-4	SCREW,MACHINE	EA	3
2	2	XBHZZ		56996	B4029258	CHASSIS,SUBASSEMBLY	EA	1
2	3	PAOZZ		96906	MS91524-2	KNOB	EA	1
2	4	PAOZZ	5305-00-984-4984	96906	MS35206-227	SCREW,MACHINE	EA	1
2	5	PAOZZ		56996	B4029353	ANTENNA	EA	1
2	6	XBHZZ		56996	B4029356	PLATE,INSTRUCTION	EA	1
2	7	XBHZZ		56996	B4029355	PLATE,INSTRUCTION	EA	1
2	8	XBHZZ		56996	B4029354	RETAINER,INSTR PL	EA	2
2	9	XBHZZ		56996	B4029273	COVER,TEST SET-TOP	EA	1
2	10	XBHZZ		56996	B4029276	SCREW,MACHINE	EA	6
2	11	XBHZZ		56996	B4029335	PLATE,IDENT	EA	1
2	12	PAOZZ	5305-00-993-0191	96906	MS35206-212	SCREW,MACHINE	EA	1
2	13	PAHZZ	6625-01-158-3001	56996	B4029268	CIRCUIT CARD ASSEMB	EA	1
2	14	PAHZZ	5305-00-889-3316	96906	MS35206-213	SCREW,MACHINE	EA	2
2	15	PAHZZ	6625-01-158-2999	56996	B4029259	CIRCUIT CARD ASSEMB	EA	1
2	16	PAHZZ	6625-01-158-3000	56996	B4029262	CIRCUIT CARD ASSEMB	EA	1
2	17	XBHZZ		56996	B4029271	RETAINER ASSY,BATT	EA	1
2	18	PAHZZ	5305-00-984-4978	96906	MS35206-221	SCREW,MACHINE	EA	4
2	19	XBHZZ		56996	B4029337	PAD,CUSHIONING	EA	4
2	20	XBHZZ		56996	B4029287	COVER,TEST SET-BOT	EA	1
2	21	XAHZZ		56996	B4029297	SCREW,EXT REL BODY	EA	4
2	22	PAHZZ	5305-00-983-6730	96906	MS35206-218	SCREW,MACHINE	EA	2
2	23	PAHZZ		56996	B4029265	CIRCUIT CARD ASSEMB	EA	1
2	24	PAHZZ	5325-00-286-6047	96906	MS35489-1	GROMMET,NONMETALLIC	EA	1
2	25	PAHZZ	5930-01-032-3826	81073	30-251BLK	SWITCH	EA	1

SECTION IV
 NATIONAL STOCK NUMBER AND PART NUMBER INDEX

TM11-6625-3015-24P

NOTE: LATEST NATIONAL STOCK NUMBER AND PART NUMBER ASSIGNMENTS ARE INCLUDED AT END OF INDEX.

STOCK NUMBER	FIGURE NO	ITEM NO	STOCK NUMBER	FIGURE NO	ITEM NO
5325-00-286-6047	2	24	5985-01-097-7337	1	3
5305-00-889-3116	2	14	6625-01-119-9910	1	1
5305-00-983-6730	2	22	6625-01-158-2999	2	1
5305-00-984-4978	2	18	6625-01-158-3000	2	16
5305-00-984-4984	2	4	6625-01-158-3001	2	13
5305-00-993-0191	2	12			

FSCM	PART NUMBER	FIGURE NO	ITEM NO	FSCM	PART NUMBER	FIGURE NO	ITEM NO
56996	B4029258	2	2	56996	B4029354	2	8
56996	B4029259	2	15	56996	B4029355	2	7
56996	B4029262	2	16	56996	B4029356	2	6
56996	B4029265	2	23	96906	MS35206-212	2	12
56996	B4029268	2	13	96906	MS35206-213	2	14
56996	B4029271	2	17	96906	MS35206-218	2	22
56996	B4029273	2	9	96906	MS35206-221	2	18
56996	B4029276	2	10	96906	MS35206-227	2	4
56996	B4029277	1	2	96906	MS35489-1	2	24
56996	B4029287	2	20	96906	MS91524-2	2	3
56996	B4029297	2	21	97539	R-4-40X1-4	2	1
56996	B4029335	2	11	80058	TS-3951/PRM-34	1	1
56996	B4029337	2	19	05726	2249C24	1	4
56996	B4029353	2	5	37695	914598-801	1	3

LATEST NATIONAL STOCK NUMBER ASSIGNMENTS

LATEST PART NUMBER ASSIGNMENTS

STOCK NUMBER	FIGURE NO.	ITEM NO.	FSCM	PART NUMBER	FIGURE NO.	ITEM NO.
5930-01-032-3826	2	25	81073	30-251BLK	2	25

RECOMMENDED CHANGES TO EQUIPMENT TECHNICAL PUBLICATIONS



THEN... JOT DOWN THE DOPE ABOUT IT ON THIS FORM. CAREFULLY TEAR IT OUT. FOLD IT AND DROP IT IN THE MAIL!

SOMETHING WRONG WITH THIS PUBLICATION?

FROM: (PRINT YOUR UNIT'S COMPLETE ADDRESS)

Commander
Stateside Army Depot
ATTN: AMSTA-US
Stateside, N.J. 07703

DATE SENT

10 July 1975

PUBLICATION NUMBER

TM 11-5840-340-12

PUBLICATION DATE

23 Jan 74

PUBLICATION TITLE

Radar Set AN/PRC-76

BE EXACT... PIN-POINT WHERE IT IS

PAGE NO	PARA-GRAPH	FIGURE NO	TABLE NO
2-25	2-28		
3-10	3-3		3-1
5-6	5-8		
		F03	

IN THIS SPACE TELL WHAT IS WRONG AND WHAT SHOULD BE DONE ABOUT IT:

Recommend that the installation antenna alignment procedure be changed throughout to specify a 2° IFF antenna lag rather than 1°.

REASON: Experience has shown that with only a 1° lag, the antenna servo system is too sensitive to wind gusting in excess of 25 knots, and has a tendency to rapidly accelerate and decelerate as it hunts, causing strain to the drive train. Hunting is minimized by adjusting the lag to 2° without degradation of operation.

Item 5, Function column. Change "2 db" to "3db."

REASON: The adjustment procedure for the TRANS POWER FAULT indicator calls for a 3 db (500 watts) adjustment to light the TRANS POWER FAULT indicator.

Add new step f.1 to read, "Replace cover plate removed in step e.1, above."

REASON: To replace the cover plate.

Zone C 3. On J1-2, change "+24 VDC to "+5 VDC."

REASON: This is the output line of the 5 VDC power supply. +24 VDC is the input voltage.

TEAR ALONG PERFORATED LINE

PRINTED NAME, GRADE OR TITLE, AND TELEPHONE NUMBER

SSG I. M. DeSpiritof 999-1776

SIGN HERE

DA FORM 2028-2
1 JUL 79

PREVIOUS EDITIONS ARE OBSOLETE.

P.S.--IF YOUR OUTFIT WANTS TO KNOW ABOUT YOUR RECOMMENDATION MAKE A CARBON COPY OF THIS AND GIVE IT TO YOUR HEADQUARTERS.

FILL IN YOUR
UNIT'S ADDRESS

FOLD BACK

DEPARTMENT OF THE ARMY

POSTAGE AND FEES PAID
DEPARTMENT OF THE ARMY
DOD 314



OFFICIAL BUSINESS
PENALTY FOR PRIVATE USE \$300

SAMPLE

Commander
US Army Communications-Electronics Command
and Fort Monmouth
ATTN: DRSEL-ME-MP
Fort Monmouth, New Jersey 07703

TEAR ALONG PERFORATED LINE

RECOMMENDED CHANGES TO EQUIPMENT TECHNICAL PUBLICATIONS



THEN...JOT DOWN THE DOPE ABOUT IT ON THIS FORM. CAREFULLY TEAR IT OUT, FOLD IT AND DROP IT IN THE MAIL.

SOMETHING WRONG WITH THIS PUBLICATION?

FROM: (PRINT YOUR UNIT'S COMPLETE ADDRESS)

DATE SENT

PUBLICATION NUMBER
TM 11-6625-3015-24P

PUBLICATION DATE
25 Feb 1984

PUBLICATION TITLE
Radio Test Set AN/PRM-34

BE EXACT PIN-POINT WHERE IT IS

PAGE
NO.

PARA-
GRAPH

FIGURE
NO.

TABLE
NO.

IN THIS SPACE TELL WHAT IS WRONG
AND WHAT SHOULD BE DONE ABOUT IT:

TEAR ALONG PERFORATED LINE

PRINTED NAME GRADE OR TITLE AND TELEPHONE NUMBER

SIGN HERE

DA FORM 2028-2
JUL 79

PREVIOUS EDITIONS
ARE OBSOLETE

P.S.--IF YOUR OUTFIT WANTS TO KNOW ABOUT YOUR
RECOMMENDATION MAKE A CARBON COPY OF THIS
AND GIVE IT TO YOUR HEADQUARTERS.

FILL IN YOUR
UNIT'S ADDRESS

FOLD BACK

DEPARTMENT OF THE ARMY

OFFICIAL BUSINESS
PENALTY FOR PRIVATE USE \$300

POSTAGE AND FEES PAID
DEPARTMENT OF THE ARMY
DOD 314



TEAR ALONG PERFORATED LINE

Commander
US Army Communications-Electronics Command
and Fort Monmouth
ATTN: DRSEL-ME-MP
Fort Monmouth, New Jersey 07703

RECOMMENDED CHANGES TO EQUIPMENT TECHNICAL PUBLICATIONS



THEN...JOT DOWN THE DOPE ABOUT IT ON THIS FORM. CAREFULLY TEAR IT OUT, FOLD IT AND DROP IT IN THE MAIL.

SOMETHING WRONG WITH THIS PUBLICATION?

FROM: (PRINT YOUR UNIT'S COMPLETE ADDRESS)

DATE SENT

PUBLICATION NUMBER
TM 11-6625-3015-24P

PUBLICATION DATE
25 Feb 1984

PUBLICATION TITLE
Radio Test Set AN/PRM-34

BE EXACT PIN-POINT WHERE IT IS

PAGE NO.	PARA-GRAPH	FIGURE NO.	TABLE NO.
----------	------------	------------	-----------

IN THIS SPACE TELL WHAT IS WRONG AND WHAT SHOULD BE DONE ABOUT IT:

TEAR ALONG PERFORATED LINE

PRINTED NAME GRADE OR TITLE AND TELEPHONE NUMBER

SIGN HERE

FILL IN YOUR
UNIT'S ADDRESS



FOLD BACK

DEPARTMENT OF THE ARMY

OFFICIAL BUSINESS
PENALTY FOR PRIVATE USE \$300

POSTAGE AND FEES PAID
DEPARTMENT OF THE ARMY
DOD 314



TEAR ALONG PERFORATED LINE

Commander
US Army Communications-Electronics Command
and Fort Monmouth
ATTN: DRSEL-ME-MP
Fort Monmouth, New Jersey 07703

RECOMMENDED CHANGES TO EQUIPMENT TECHNICAL PUBLICATIONS



THEN...JOT DOWN THE DOPE ABOUT IT ON THIS FORM. CAREFULLY TEAR IT OUT, FOLD IT AND DROP IT IN THE MAIL.

SOMETHING WRONG WITH THIS PUBLICATION?

FROM: (PRINT YOUR UNIT'S COMPLETE ADDRESS)

DATE SENT

PUBLICATION NUMBER

TM 11-6625-3015-24P

PUBLICATION DATE

29 Feb 1984

PUBLICATION TITLE

Radio Test Set AN/PRM-34

BE EXACT PIN-POINT WHERE IT IS

PAGE NO.

PARA-GRAPH

FIGURE NO.

TABLE NO.

IN THIS SPACE TELL WHAT IS WRONG AND WHAT SHOULD BE DONE ABOUT IT:

TEAR ALONG PERFORATED LINE

PRINTED NAME GRADE OR TITLE AND TELEPHONE NUMBER

SIGN HERE

FILL IN YOUR
UNIT'S ADDRESS

FOLD BACK

DEPARTMENT OF THE ARMY

OFFICIAL BUSINESS
PENALTY FOR PRIVATE USE \$300

POSTAGE AND FEES PAID
DEPARTMENT OF THE ARMY
DOD 314



TEAR ALONG PERFORATED LINE

Commander
US Army Communications-Electronics Command
and Fort Monmouth
ATTN: DRSEL-ME-MP
Fort Monmouth, New Jersey 07703

By Order of the Secretary of the Army:

Official:

JOHN A. WICKHAM JR.
General, United States Army
Chief of Staff

ROBERT M. JOYCE
Major General, United States Army
The Adjutant General

DISTRIBUTION:

To be distributed in accordance with DA Form 12-51 requirements
for AN/VRC-12.

PROPERTY OF US ARMY

TECHNICAL LIBRARY
US ARMY MAINTENANCE MANAGEMENT CENTER
LEXINGTON, KY 40511

